

Shaft dia. mm inch	Unit number	Nominal dimensions															Bearing number	Housing number	Mass of unit Kg
		mm inch																	
		<i>o</i>	<i>g</i>	<i>p</i>	<i>q</i>	<i>s</i>	<i>b</i>	<i>k</i>	<i>e</i>	<i>a</i>	<i>w</i>	<i>j</i>	<i>t</i>	<i>h</i>	<i>Bi</i>	<i>n</i>			
12 1/2	UEL201	16	12	51	32	19	51	12	76	89	94	32	21	61	43.5	17.0	UEL201	T 204	0.83
	UEL201-8	5/8	25/64	2-1/64	1-17/64	3/4	2-1/64	15/32	2-63/64	3-1/2	3-45/64	1-17/64	53/64	2-13/32	1.7126	0.6693	UEL201-8		0.83
15 5/8	UEL202	16	12	51	32	19	51	12	76	89	94	32	21	61	43.5	17.0	UEL202	T 204	0.81
	UEL202-10	5/8	25/64	2-1/64	1-17/64	3/4	2-1/64	15/32	2-63/64	3-1/2	3-45/64	1-17/64	53/64	2-13/32	1.7126	0.6693	UEL202-10		0.81
17 11/16	UEL203	16	12	51	32	19	51	12	76	89	94	32	21	61	43.5	17.0	UEL203	T 204	0.80
	UEL203-11	5/8	25/64	2-1/64	1-17/64	3/4	2-1/64	15/32	2-63/64	3-1/2	3-45/64	1-17/64	53/64	2-13/32	1.7126	0.6693	UEL203-11		0.80
20 3/4	UEL204	16	12	51	32	19	51	12	76	89	94	32	21	61	43.5	17.0	UEL204	T 204	0.78
	UEL204-12	5/8	25/64	2-1/64	1-17/64	3/4	2-1/64	15/32	2-63/64	3-1/2	3-45/64	1-17/64	53/64	2-13/32	1.7126	0.6693	UEL204-12		0.79
25 1	UEL205	16	12	51	32	19	51	12	76	89	97	32	24	62	44.3	17.4	UEL205	T 205	0.87
	UEL205-16	5/8	25/64	2-1/64	1-17/64	3/4	2-1/64	15/32	2-63/64	3-1/2	3-13/16	1-17/64	15/16	2-7/16	1.7441	0.6850	UEL205-16		0.86
30 1-1/8 1-1/4	UEL206	16	12	56	37	22	57	12	89	102	113	37	28	70	48.3	18.2	UEL206	T 206	1.35
	UEL206-18	5/8	25/64	13/64	1-29/64	55/64	2-1/4	15/32	3-1/2	4-1/64	4-29/64	1-29/64	1-7/64	2-3/4	1.9016	0.7165	UEL206-18		1.37
	UEL206-20	5/8	25/64	13/64	1-29/64	55/64	2-1/4	15/32	3-1/2	4-1/64	4-29/64	1-29/64	1-7/64	2-3/4	1.9016	0.7165	UEL206-20		1.32
35 1-1/4 1-3/8	UEL207	16	15	64	37	22	64	12	89	102	129	37	30	78	51.1	18.8	UEL207	T 207	1.71
	UEL207-20	5/8	3/64	2-3/64	1-29/64	55/64	2-3/64	15/32	3-1/2	4-1/64	5-5/64	1-29/64	1-3/16	3-5/64	2.0118	0.7402	UEL207-20		1.79
	UEL207-22	5/8	3/64	2-3/64	1-29/64	55/64	2-3/64	15/32	3-1/2	4-1/64	5-5/64	1-29/64	1-3/16	3-5/64	2.0118	0.7402	UEL207-22		1.72
40 1-1/2	UEL208	19	18	83	49	29	83	16	102	114	144	49	33	88	56.3	21.4	UEL208	T 208	2.45
	UEL208-24	3/4	5/8	3-17/64	1-59/64	1-9/64	3-17/64	5/8	4-1/64	4-31/64	5-43/64	1-59/64	1-19/64	3-15/32	2.2165	0.8425	UEL208-24		2.50
45 1-5/8 1-3/4	UEL209	19	18	83	49	29	83	16	102	117	144	49	35	87	56.3	21.4	UEL209	T 209	2.45
	UEL209-26	3/4	5/8	3-17/64	1-59/64	1-9/64	3-17/64	5/8	4-1/64	4-39/64	5-43/64	1-59/64	1-3/8	3-27/64	2.2165	0.8425	UEL209-26		2.56
	UEL209-28	3/4	5/8	3-17/64	1-59/64	1-9/64	3-17/64	5/8	4-1/64	4-39/64	5-43/64	1-59/64	1-3/8	3-27/64	2.2165	0.8425	UEL209-28		2.47
50 1-7/8	UEL210	19	18	83	49	29	86	16	102	117	149	49	37	90	62.7	24.6	UEL210	T 210	2.71
	UEL210-30	3/4	5/8	3-17/64	1-59/64	1-9/64	3-25/64	5/8	4-1/64	4-39/64	5-55/64	1-59/64	1-29/64	3-35/64	2.4685	0.9685	UEL210-30		2.80
55 2	UEL211	25	21	102	64	35	95	22	130	146	171	64	38	106	71.4	27.7	UEL211	T 211	4.06
	UEL211-32	63/64	3/4	4-1/64	2-3/64	1-3/8	3-47/64	55/64	5-1/8	5-3/4	6-47/64	2-3/64	1-1/2	4-11/64	2.8110	1.0906	UEL211-32		4.25
60 2-1/4	UEL212	32	21	102	64	35	102	22	130	146	194	64	42	119	77.8	30.9	UEL212	T 212	5.13
	UEL212-36	1-17/64	3/4	4-1/64	2-3/64	1-3/8	4-1/64	55/64	5-1/8	5-3/4	7-41/64	2-3/64	1-21/32	4-11/16	3.0630	1.2165	UEL212-36		5.29
65 2-1/2	UEL213	32	23	111	70	41	121	26	151	167	224	70	44	137	85.7	34.1	UEL213	T 213	7.21
	UEL213-40	1-17/64	53/64	4-3/8	2-3/4	1-39/64	4-49/64	1-1/64	5-15/16	6-37/64	8-13/16	2-3/4	1-47/64	5-25/64	3.3740	1.3425	UEL213-40		7.31
70 2-3/4	UEL214	32	23	111	70	41	121	26	151	167	224	70	46	137	85.7	34.1	UEL214	T 214	7.27
	UEL214-44	1-17/64	53/64	4-3/8	2-3/4	1-39/64	4-49/64	1-1/64	5-15/16	6-37/64	8-13/16	2-3/4	1-13/16	5-25/64	3.3740	1.3425	UEL214-44		7.28

Remark: 1) Regular production in "J" tolerance.  
 2) Bearing unit with grease holes and grease groove.  
 3) Bearing unit without stop pin.

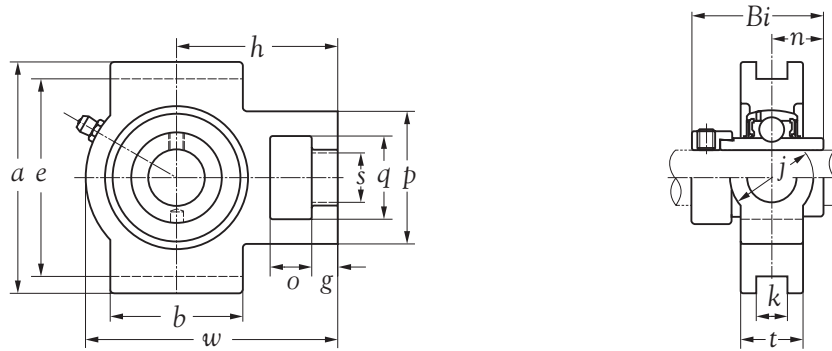

Shaft dia. mm inch	Unit number	Nominal dimensions														Bearing number	Housing number	Mass of unit Kg	
		o	g	p	q	s	b	k	e	a	w	j	t	h	Bi				n
75 3	UEL T 215	32	23	111	70	41	121	26	151	167	232	70	48	140	92.1	37.3	UEL 215	T 215	7.74
	UEL T 215-48	1-17/64	53/64	4-3/8	2-3/4	1-39/64	4-49/64	1-1/64	5-15/16	6-37/64	9-9/64	2-3/4	1-57/64	5-3/64	3.6260	1.4685	UEL 215-48		7.64

- Remark: 1) Regular production in "J" tolerance.  
 2) Bearing unit with grease holes and grease groove.  
 3) Bearing unit without stop pin.